

# FA 315

FULLY AUTOMATIC / TAM OTOMATİK

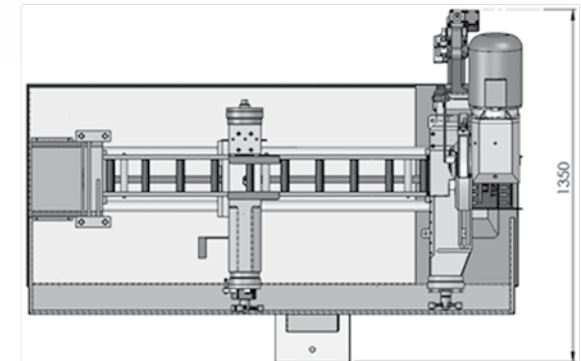
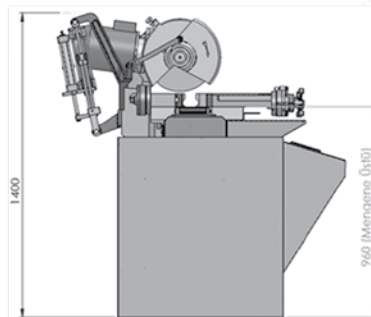
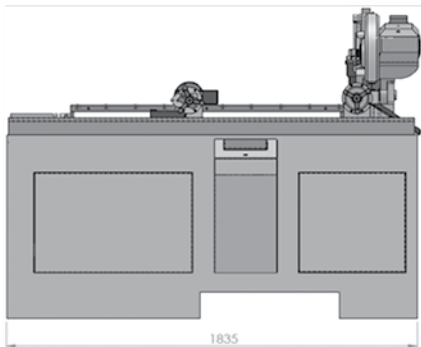

## TECHNICAL FEATURES

- Fully automatic machine for straight tube cutting
- Servo motor controlled material feeding system with ball screw
- Hydro-pneumatic operation of saw head smoothes descent for optimum cut
- PLC controlled colour type touch screen display
- Up to 1.000 mm single material feeding
- Over 1.000 mm multiply feeding
- 4 different cutting length adjustment in one material
- $\pm 0,3$  mm cutting length precision
- High performance gear box designed in accordance with continuous working conditions (helical gears and worm gear set)
- 2 speed main motor
- Coolant tank with box to collect chips and electrical lubrication pump for blade lubrication and cooling

### Optional Accessories:

- Material support roller
- Saw Blade

## TEKNİK ÖZELLİKLER:

- Tam otomatik düz kesim testere makinesi
- Servo motor ve vidalı mil kontrollü malzeme sürücüsü
- Hidro-pnömatik çalışan testere kafası sayesinde ayarlanabilir ve kontrol edilebilir kesme hızı,
- PLC kontrollü dokunmatik ekran
- 1000 mm'ye kadar tek seferde sürme ve kesme
- 1000 mm üzeri çoklu sürme,
- Aynı malzeme üzerinde 4 farklı boyda kesme imkanı
- Çift devirli motor sayesinde malzeme özelliklerine göre en uygun devri seçebilme,
- Yüksek performanslı ve çift helis dişli aktarmalı redüktör yapısı
- $+0,3$  mm hassasiyette boy ayarı (kullanılan testerenin salgısına bağlı olarak bu değer değişebilir)

CUTTING CAPACITY KESME KAPASİTESİ		
Maximum Saw Blade Size $\varnothing$ Maksimum Testere Çapı $\varnothing$	315 mm	
Head Swivel Testere Açısı	90°	45°
Round (mm) Yuvarlak	100	-
Square (mm) Kare (mm)	80 x 80	-
Rectangle (mm) Dikdörtgen (mm)	110 x 80	-
Min. Rest Part (mm) Min. Son Kalan Parça Boyu (Fire)	120	

TECHNICAL SPECIFICATIONS TEKNİK ÖZELLİKLER		
Main Voltage (V) Ana Voltaj	400	
Control Voltage (V) Kontrol Voltajı (V)	24	
Installed Power (kW) Kurulu Güç (kW)	3	
Nominal Current (A) Akım (A)	10,2	
Main Saw Motor (kW) Testere Motoru (kW)	1,8 - 2,2	
Coolant Pump Motor (kW) Bor Yağı Pompası (kW)	0,06	
Air Pressure (Consumption) Hava Basıncı	6 kg/cm <sup>2</sup> (240 l/min)	
Blade Speed (RPM) Testere Devri (Devir/Dk)	40/80	
Head Swivel Açı Dönüşü	90°	
Saw Blade Size Testere Çapı (mm)	Diameter Dış Çap	315
	Bore Delik Çapı	32
	Pin Holes Pim Delikleri	2 x $\varnothing 11$ / Pivot Center $\varnothing 63$
Machine Dimensions (LxWxH) cm Makine Ölçüleri (En x Boy x Yükseklik) cm	190 x 140 x 160	
Packing Dimensions (LxWxH) cm Paketlenmiş Makine Ölçüleri (En x Boy x Yükseklik) cm	200 x 145 x 170	
Net Weight (Kg) Net Ağırlık (Kg)	620	
Gross Weight (Kg) Brüt Ağırlık (Kg)	650	

